

Corporate Profile

Installations, Inc. has been in business for over 25 years specializing in the fabrication and installation of security enclosures. Installations has a full product line of security accessories, bullet resistant opaque armor and bullet resistant glazing materials to custom fabricate a security enclosure to meet your needs.

From our sales department, through the engineering department, and into our fabrication facility Installations, Inc. has a full staff of experienced employees to serve you. Installations also have professional installations crews to install the job for you. From design through the installation we will be there for you to create your own state of the art security enclosure.

With Installations wide range of security products and ballistic levels we can service your specific needs. Banks, fast food restaurants, convenience stores, utility payment centers and corporate security all have different needs, and Installations has the versatility, knowledge and capabilities to help you. Whether it is a retail establishment or a Government facility the ballistic level may change but the service and craftsmanship will not.

Installations product lines have expanded through the years to meet the changing times. Customers expect and should receive a security system that is both secure and visually appealing. With a full line of glazing options, opaque armor, security doors, package exchange units, transaction windows, and framing systems, Installations can help you meet your security needs.

Installations sales and engineering staff are on hand to help you with your security needs. Whether you need design consultation, product literature, fabrication or installation, please contact us for your security needs.

Counterline Security Enclosures

Installations, Inc. can fabricate several styles of security enclosures that are aesthetically appealing. Installations sales and engineering staff are on hand to help you with your security needs. Whether you need design consultation, product literature, fabrication or installation, please contact us for your security needs.

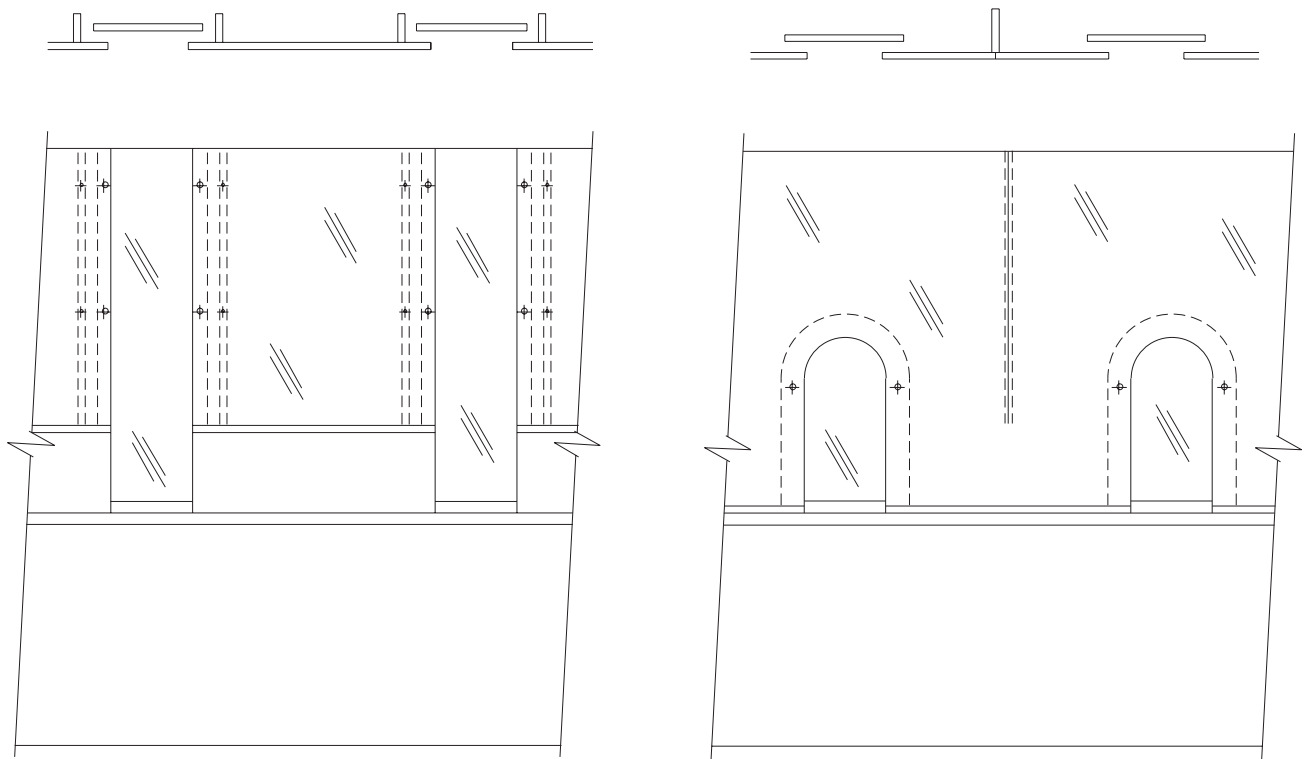

Vertical Baffle System

Product Description:

Installations Vertical Baffle System (VBS) is custom engineered and fabricated to be installed on your existing teller line. The system can be installed by Installation, Inc's professional installation crew or an approved/trained installation crew. The systems allow for natural voice transmission and can be supplied with stainless steel money trays and package exchange units for large packages.

Bullet Resistant Options:

Level I	1 1/4" uncoated acrylic
Level I	1 1/4" abrasion resistant acrylic
Level II	1 3/8" abrasion resistant acrylic
Level III	1 1/4" SP Polycast

Aluminum Finish Options:

Clear Anodized
Bronze Anodized
Custom anodizing and painting available upon request

Recommended Uses:

- Financial Institutions
- Convenience Stores
- Fast Food Operations
- Police Stations

Benefits and Features:

- UL listed level I, II & III glazing materials
- Custom built to fit your existing counter
- Full vision system
- Delivered complete and ready for installation

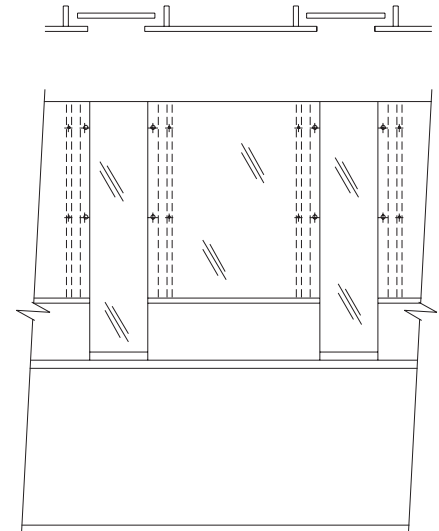

With Hood

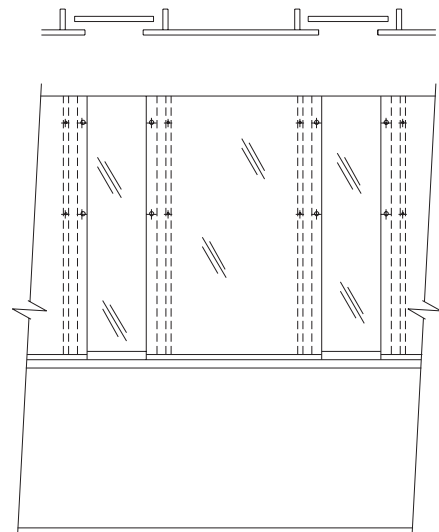

Without Hood

From our sales and engineering department to our fabrication facility, Installations, Inc. has a full staff of experienced employees to serve you. Please contact our sales department or your local representative to assist you with all of your bullet resistant needs.

phone 1.800.442.2290 fax 1.313.532.0894

Arched Window System

Product Description

Installations Arched Window System (AWS) is custom engineered and fabricated to be installed on your existing teller line. The system can be installed by Installation, Inc's professional installation crew or an approved / trained installation crew. The systems allow for natural voice transmission and can be supplied with stainless steel money trays and package exchange units for large packages.

Bullet Resistant Options:

Level I	1 1/4" uncoated acrylic
Level I	1 1/4" abrasion resistant acrylic
Level II	1 3/8" abrasion resistant acrylic
Level III	1 1/4" SP Polycast

Aluminum Finish Options:

Clear Anodized
Bronze Anodized
Custom anodizing and painting available upon request

Recommended Uses:

- Financial Institutions
- Convenience Stores
- Fast Food Operations
- Police Stations

Benefits and Features:

- UL listed level I, II & III glazing materials
- Custom built to fit your existing counter
- Full vision system
- Delivered complete and ready for installation

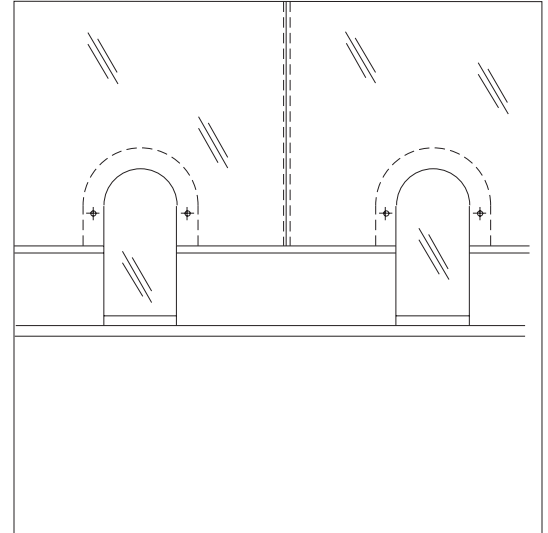

Level I Uncoated Acrylic

Product Description:

The level I bullet resistant acrylic is a 1 1/4" thick UL tested and rated level I cell-cast acrylic sheet that can be easily fabricated into a custom security enclosure to fit your needs.

Technical Information:

BR Level	1
Thickness	1 1/4"
Weight	7.6 lbs.
Light transmission	90%

Recommended Uses:

- Financial Institutions
- Convenience Stores
- Gas Stations
- Fast Food Operations
- Police Stations

Benefits and Features:

- Easy cleaning
- Lightweight
- 90% light transmission
- Custom fabrication

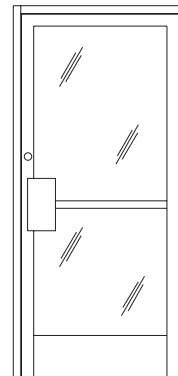
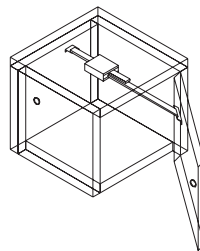
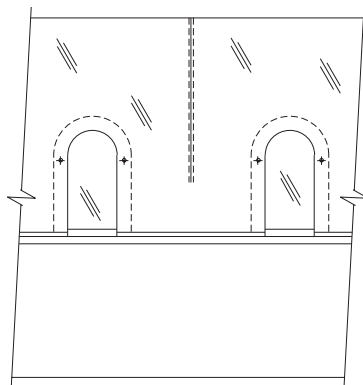
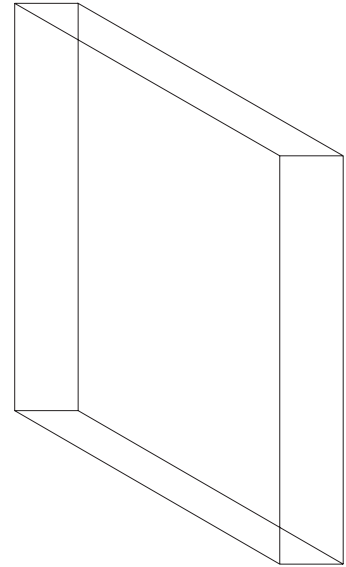

Level I Abrasion Resistant Acrylic

Product Description:

The level I bullet abrasion resistant acrylic is a 1 1/4" thick UL tested and rated level I cell-cast acrylic sheet that can be easily fabricated into a custom security enclosure to fit your needs.

Technical Information:

BR Level	1
Thickness	1 1/4"
Weight	7.6 lbs.
Light transmission	90%

Recommended Uses:

- Financial Institutions
- Convenience Stores
- Gas Stations
- Fast Food Operations
- Police Stations

Benefits and Features:

- Abrasion resistant coating
- Easy cleaning
- Lightweight
- 90% light transmission
- Custom fabrication

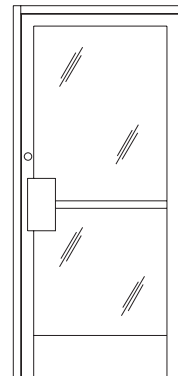
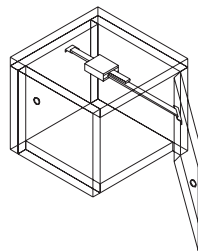
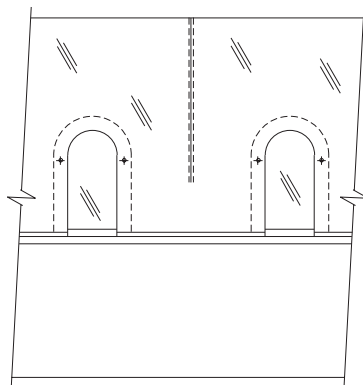
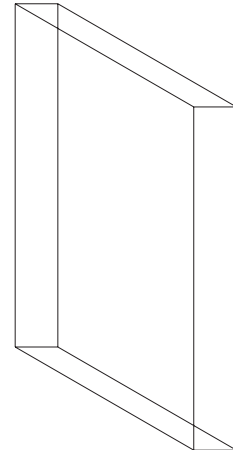

Level II Abrasion Resistant Acrylic

Product Description:

The level II bullet abrasion resistant acrylic is a 1 3/8" thick UL tested and rated level II cell-cast acrylic sheet that can be easily fabricated into a custom security enclosure to fit your needs.

Technical Information:

BR Level	2
Thickness	1 3/8"
Weight	8.5 lbs.
Light transmission	90%

Recommended Uses:

- Financial Institutions
- Convenience Stores
- Gas Stations
- Fast Food Operations
- Police Stations

Benefits and Features:

- Abrasion resistant coating
- Easy cleaning
- Lightweight
- 90% light transmission
- Custom fabrication

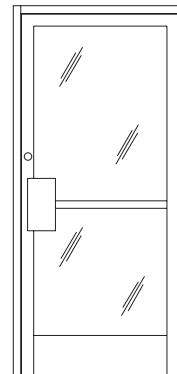
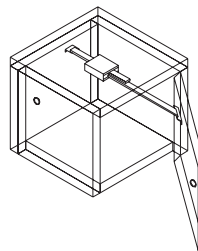
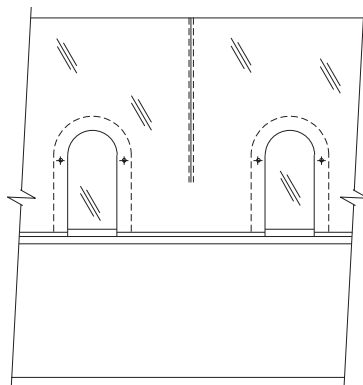
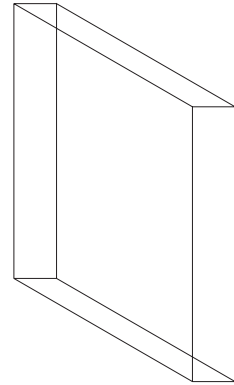

From our sales and engineering department to our fabrication facility, Installations, Inc. has a full staff of experienced employees to serve you. Please contact our sales department or your local representative to assist you with all of your bullet resistant needs.

phone 1.800.442.2290 fax 1.313.532.0894

Level III HP Polycast

Product Description:

The level III bullet abrasion resistant material is a 1 1/4" thick UL tested and rated level III multi-layered sheet with an acrylic core and polycarbonate outer layers that can be easily fabricated into a custom security enclosure to fit your needs.

Technical Information:

BR Level	3
Thickness	1 1/4"
Weight	7.8 lbs.
Light transmission	85 %

Recommended Uses:

- Financial Institutions
- Convenience Stores
- Gas Stations
- Fast Food Operations
- Police Stations

Benefits and Features:

- Abrasion resistant coating
- Easy cleaning
- Lightweight
- 90% light transmission
- Custom fabrication

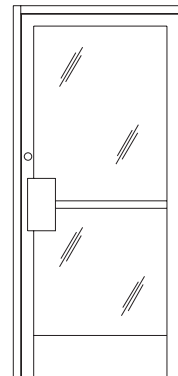
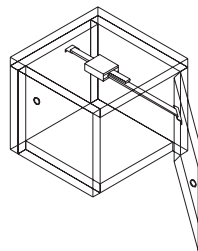
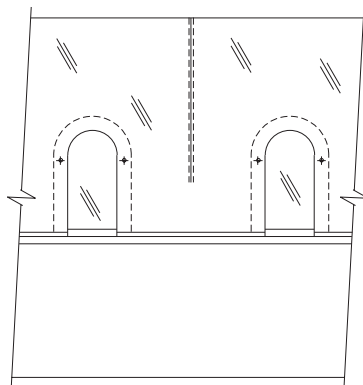
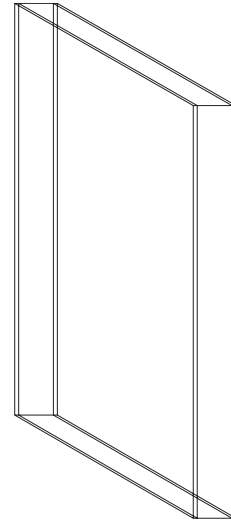

From our sales and engineering department to our fabrication facility, Installations, Inc. has a full staff of experienced employees to serve you. Please contact our sales department or your local representative to assist you with all of your bullet resistant needs.

phone 1.800.442.2290 fax 1.313.532.0894

Bullet Resistant Fiberglass

Product Description:

A multi-ply laminated ballistic fiberglass material available in levels 1 through 8. The ballistic fiberglass is lightweight and easy to fabricate.

Recommended Uses:

- Financial Institutions
- Convenience Stores
- Gas Stations
- Fast Food Operations
- Police Stations

Benefits and Features:

- Easy to install
- Lightweight
- No-Spalling

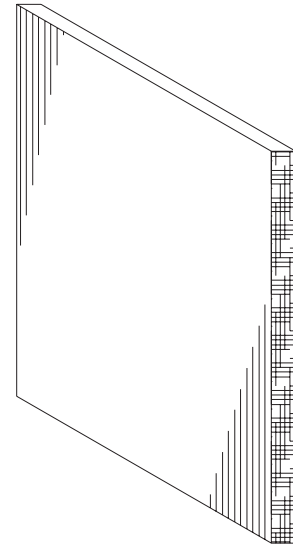

Bullet Resistant Options:

Product	BR Level	Test Criteria	Ballistic Data	Thickness	Weight
BB-1	Level 1	UL 752/ MPSA	9 mm, 124 Gr., 1175 Ft. Sec., FMJ	9/32"	3.0 lbs.
	Level 1	NIJ 0108.01/IIA	.38 Spcl., 158 Gr., 850 Ft. Sec., Lead		
BB-2	Level 2	UL 752/HPSA	.357 Mag., 158 Gr., 1250 Ft. Sec., LSP	3/8"	3.5 lbs.
	Level 6	UL 752/HPSA	9mm Auto, 124 Gr., 1400 Ft. Sec., FMJ		
	Level 2A	NIJ 0108.01/II	9mm Auto, 124 Gr., 1090 Ft. Sec., FMJ		
	Level 2	NIJ 0108.01/II	.357 Mag., 158 Gr., 1395 Ft. Sec., JSP		
BB-3	Level 3	UL 752/SPSA	.44 Mag., 240 Gr., 1350 Ft. Sec. SWC	1/2"	5.0 lbs.
	Level 3A	NIJ 0108.01/IIIA	.44 Mag., 240 Gr., 1400 Ft. Sec. SWC		
BB-4	Level 4	UL 752/HPR	.30 Cal., 180 Gr., 2540 Ft. Sec., JSP	1 1/4"	13.5
	Level 5	UL 752/HPR	7.62 Nato, 150 Gr., 2750 Ft. Sec., FMJ		
	Level 7	UL 752/HPR	5.56mm, 55 Gr., 3080 Ft., Sec., FMJ		
	Level 8	UL 752/HPR	7.62mm, 150 Gr., 2750 Ft. Sec., FMJ		
	Level 2	NIJ 0108.01/II	7.62mm, 150 Gr., 2750 Ft. Sec., FMJ		

From our sales and engineering department to our fabrication facility, Installations, Inc. has a full staff of experienced employees to serve you. Please contact our sales department or your local representative to assist you with all of your bullet resistant needs.

phone 1.800.442.2290 fax 1.313.532.0894

UL 752 Testing

BR Level	Weapon and Ammunition	Weight & Grains		Minimum Velocity	Maximum Range	Number of Shots
1	9 mm full metal copper jacket with lead core	124	8.0 grains	1175 fps	110%	3
2	.357 magnum jacketed lead soft point	158	10.2 grains	1250 fps	110%	3
3	.44 magnum lead semi- wadcutter gas checked	240	15.6 grains	1350 fps	110%	3
4	.30 caliber rifle lead core soft point	180	11.7 grains	2540 fps	110%	1
5	7.62 mm rifle lead core full metal jacket, military ball	150	9.7 grains	2750 fps	110%	1
6	9 mm full metal copper jacket with lead core	124	8.0 grains	1400 fps	110%	5
7	5.56 mm rifle full metal copper jacket with lead core	55	8.56 grains	3080 fps	110%	5
8	7.62 mm rifle lead core full metal copper jacket, military ball	150	9.7 grains	2750 fps	110%	5
*SSG	12 gauge rifled lead slug and 12 gauge 00 lead buckshot (12 pellets)	437	(28.3 gr)	1585 fps	110%	3
		650	(42 gr)	1200 fps	110%	3

* Supplementary Shotgun

NIJ 018.01 Test Ratings Chart

BR Level	Weapon and Ammunition	Weight & Grains		Minimum Velocity	Maximum Range	Number of Shots	Barrel Length
I	.22 long rifle high velocity	40	2.6 grains	320	1050	5	6 to 6.5"
I	.38 special round nose lead	158	10.2 grains	259	850	5	6"
II-A	.357 magnum jacketed soft point	158	10.2 grains	381	1250	5	4 to 4.75"
II-A	9 mm full metal jacket	124	8.0 grains	332	1090	5	4 to 4.75"
II	.357 magnum jacketed soft point	158	10.2 grains	425	1395	5	6 to 6.5"
II	9 mm full metal copper jacket with lead core	124	8.0 grains	358	1175	5	4 to 4.75"
III-A	.44 magnum lead semiwad cutter gas checked	240	15.55 grains	426	1400	5	5.5 to 6.25"
III-A	9 mm full metal jacket	124	8.0 grains	426	1400	5	9.5 to 10.25"
III	7.62 mm full metal jacket	150	9.7 grains	838	2750	5	22"
IV	30.06 armor piercing	166	10.8 grains	866	2850	1	22"

From our sales and engineering department to our fabrication facility, Installations, Inc. has a full staff of experienced employees to serve you. Please contact our sales department or your local representative to assist you with all of your bullet resistant needs.

phone 1.800.442.2290 fax 1.313.532.0894

Opaque Security Doors

Product Description:

Installations opaque security doors are custom built with a lumber core and can be provided with either a plastic laminate finish or a veneer finish. The doors are lined with UL rated bullet resistant fiberglass to meet your specifications. The doors can also be provided with a peep hole or a view window. The doors come complete with an aluminum frame and standard hardware.

Standard Hardware:

Continuous hinge, surface closer, entrance lockset, two piece door stop, electric strike release and anti-jimmy plate.

Bullet Resistant Options:

- Level I
- Level II
- Level III

Aluminum Finish Options:

- Clear Anodized
- Bronze Anodized
- Custom anodizing and painting available upon request

Recommended Uses:

- Financial Institutions
- Convenience Stores
- Fast Food Operations
- Police Stations

Benefits and Features:

- UL listed level I, II & III opaque armor
- Custom built to fit your existing opening
- Laminated to match your existing decor
- Delivered complete and ready for installation

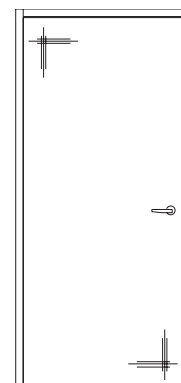
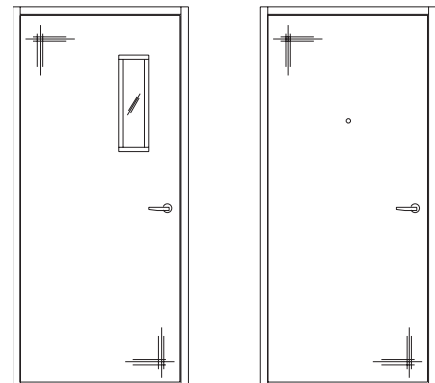
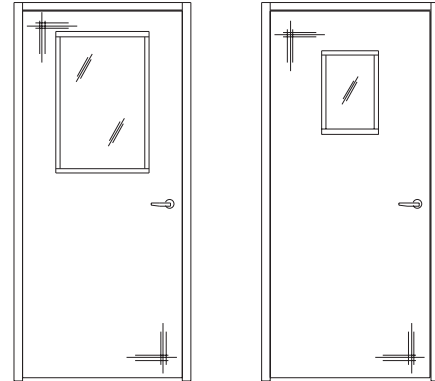

Half or Full Vision Security Door

Product Description:

Installations half vision security doors are custom built with Level I, II and III glazing material to meet your specifications. The bottom portion of the door is covered with a plastic laminate finished panel. Installations full vision security doors are custom built with level I, II and III glazing materials to meet your specifications. The doors come complete with an aluminum frame and standard hardware.

Standard Hardware:

Continuous hinge, surface closer, entrance lockset, two piece door stop, electric strike release and anti-jimmy plate.

Bullet Resistant Options:

Level I	1 1/4" uncoated acrylic
Level I	1 1/4" abrasion resistant acrylic
Level II	1 3/8" abrasion resistant acrylic
Level III	1 1/4" SP Polycast

Aluminum Finish Options:

Clear Anodized
Bronze Anodized
Custom anodizing and painting available upon request

Recommended Uses:

- Financial Institutions
- Convenience Stores
- Fast Food Operations
- Police Stations

Benefits and Features:

- UL listed level I, II & III glazing materials
- Custom built to fit your existing opening
- Full or Half vision door
- Delivered complete and ready for installation

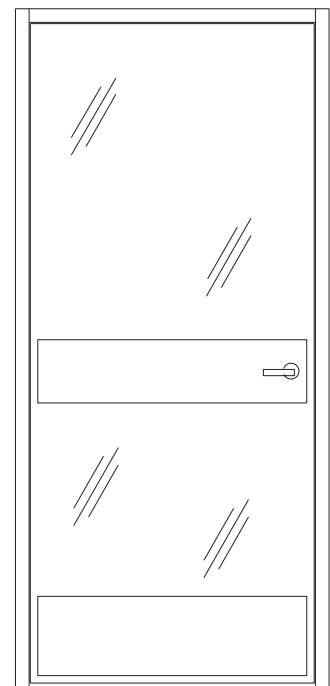
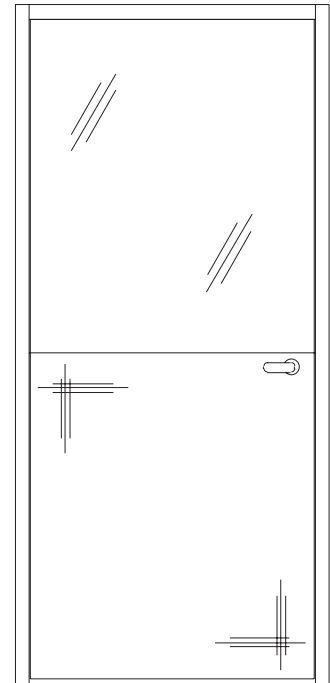

Aluminum Stile Security Door

Product Description:

Installations aluminum stile security doors are custom built with aluminum frames, top rails and stiles and can be glazed with bullet resistant glazing materials to meet your specifications. The doors can also be provided as a half lite door by glazing the bottom portion with a plastic laminate finished panel lined with ballistic fiberglass. The doors come standard with a heavy duty continuous hinge, overhead surface closer, Adams Rite deadlatch with cylinder, two piece door stop and anti-jimmy plate.

Bullet Resistant Options:

Level I	1 1/4" uncoated acrylic
Level I	1 1/4" abrasion resistant acrylic
Level II	1 3/8" abrasion resistant acrylic
Level III	1 1/4" SP Polycast

Aluminum Finish Options:

Clear Anodized
Bronze Anodized
Custom anodizing and painting available upon request

Recommended Uses:

- Convenience Stores
- Gas Stations
- Fast Food Operations
- Police Stations

Benefits and Features:

- UL listed level I, II & III glazing materials
- Custom built to fit your existing openings
- Hardware is ADA compliant
- Delivered complete and ready for installation

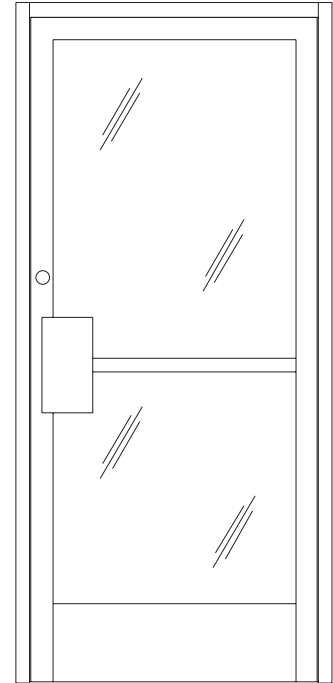

From our sales and engineering department to our fabrication facility, Installations, Inc. has a full staff of experienced employees to serve you. Please contact our sales department or your local representative to assist you with all of your bullet resistant needs.

phone 1.800.442.2290 fax 1.313.532.0894

Operable Security Enclosures

Installations, Inc. can fabricate several styles of operable window units that are aesthetically appealing. Installations sales and engineering staff are on hand to help you with your security needs. Whether you need design consultation, product literature, fabrication or installation, please contact us for your security needs.

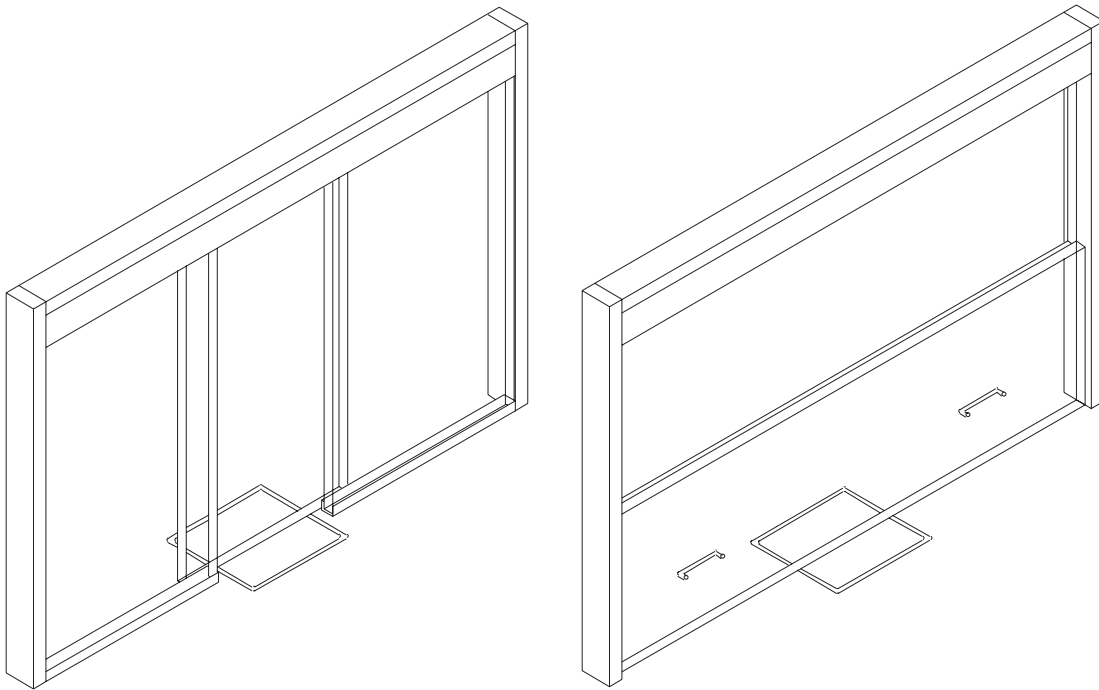

Horizontal Sliding Window Unit

Product Description:

Installations horizontal sliding security system is designed for open transaction during daylight operations and can be put into the closed and locked position during night time operations. The slider is suspended from the soffit and slides on box track that can be concealed in an existing pocket or we can construct a header for you out of aluminum or wood with a plastic laminate finish to match your existing decor. The units spacing allows for natural voice transmission and can be supplied with a stainless steel money tray designed to pass a carton of cigarettes.

Bullet Resistant Options:

Level I	1 1/4" uncoated acrylic
Level I	1 1/4" abrasion resistant acrylic
Level II	1 3/8" abrasion resistant acrylic
Level III	1 1/4" SP Polycast

Aluminum Finish Options:

Clear Anodized
Bronze Anodized
Custom anodizing and painting available upon request

Recommended Uses:

- Convenience Stores
- Gas Stations
- Fast Food Operations
- Police Stations

Benefits and Features:

- UL listed level I, II & III glazing materials
- Custom built to fit your existing counter
- Full vision system
- Delivered complete and ready for installation

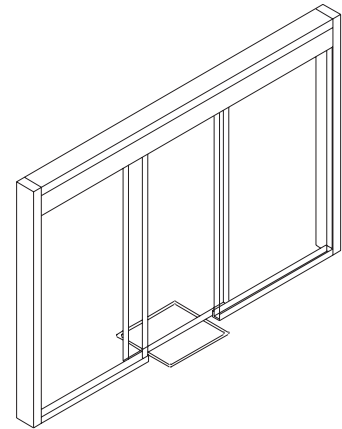
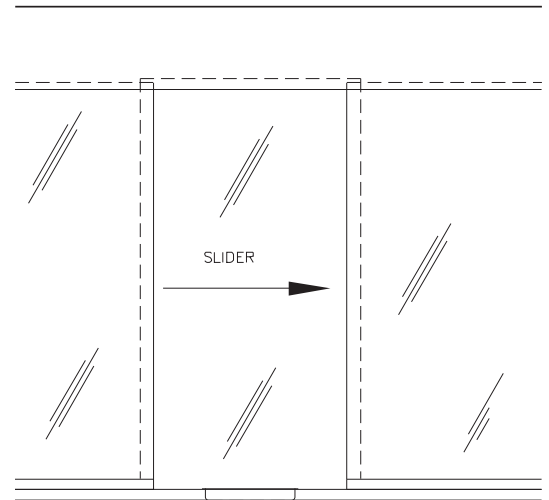

Vertical Sliding Window Unit with Counterweights

Product Description:

Installations vertical sliding security system is designed for open transactions during daylight operations and can be put into the closed and locked position during night time operations. The unit is constructed with an aluminum tube frame and the counterweights are concealed in the vertical jamb. The units spacing allows for natural voice transmission and can be supplied with a stainless steel money tray designed to pass a carton of cigarettes.

Bullet Resistant Options:

Level I	1 1/4" uncoated acrylic
Level I	1 1/4" abrasion resistant acrylic
Level II	1 3/8" abrasion resistant acrylic
Level III	1 1/4" SP Polycast

Aluminum Finish Options:

Clear Anodized
Bronze Anodized
Custom anodizing and painting available upon request

Recommended Uses:

- Convenience Stores
- Gas Stations
- Fast Food Operations
- Police Stations

Benefits and Features:

- UL listed level I, II & III glazing materials
- Custom built to fit your existing counter
- Delivered complete and ready for installation

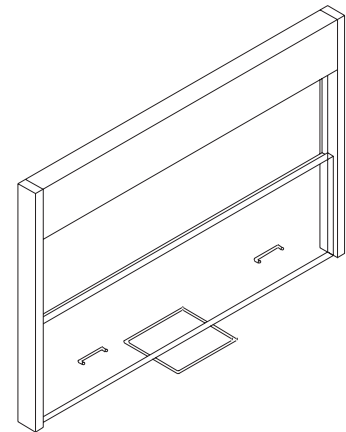
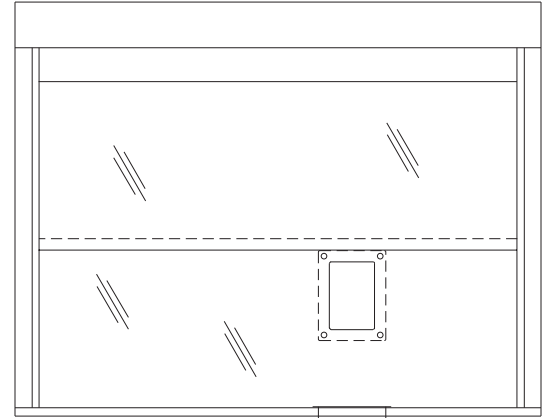

Vertical Sliding Window Unit With Counterbalances

Product Description

Installations vertical sliding security system is designed for open transactions during daylight operations and can be put into the closed and locked position during night time operations. The unit is constructed with an aluminum tube frame and the counterbalances are concealed in the aluminum header. The units spacing allows for natural voice transmission and can be supplied with a stainless steel money tray designed to pass a carton of cigarettes.

Bullet Resistant Options:

Level I	1 1/4" uncoated acrylic
Level I	1 1/4" abrasion resistant acrylic
Level II	1 3/8" abrasion resistant acrylic
Level III	1 1/4" SP Polycast

Aluminum Finish Options:

Clear Anodized
Bronze Anodized
Custom anodizing and painting available upon request

Recommended Uses:

- Convenience Stores
- Gas Stations
- Fast Food Operations
- Police Stations

Benefits and Features:

- UL listed level I, II & III glazing materials
- Custom built to fit your existing counter
- Delivered complete and ready for installation

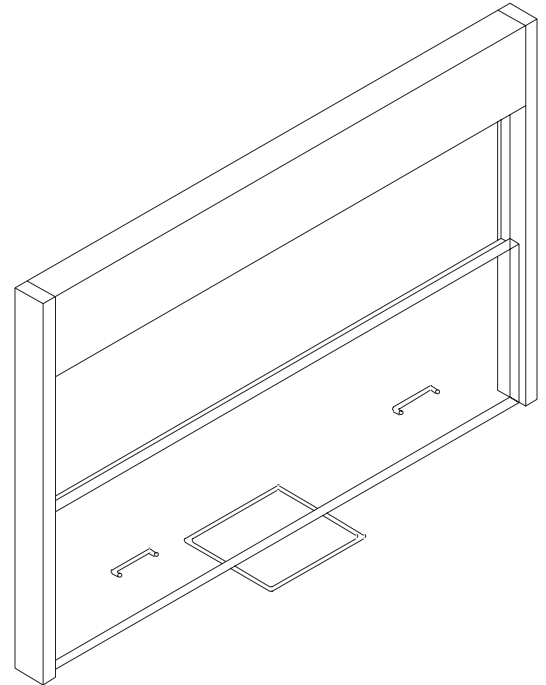

Interior or Exterior Transaction Window

Product Description:

Installations interior transaction window is designed for easy installation within an existing wall opening. The interior unit is constructed with stainless steel voice tubes and a plastic laminate finished countertop with an integral recessed stainless steel money tray. The voice rails allow for natural voice transmission. The unit is shipped assembled and ready for installation. Installations exterior unit is fabricated with a stainless steel countertop and weathersealed to prevent draft.

Bullet Resistant Options:

Level I	1 1/4" uncoated acrylic
Level I	1 1/4" abrasion resistant acrylic
Level II	1 3/8" abrasion resistant acrylic
Level III	1 1/4" SP Polycast

Aluminum Finish Options:

Clear Anodized
Bronze Anodized
Custom anodizing and painting available upon request

Recommended Uses:

- Ticket windows
- Payment centers
- Walk up windows
- Police Stations

Benefits and Features:

- UL listed level I, II & III glazing materials
- Custom built to fit your existing opening
- Delivered complete and ready for installation

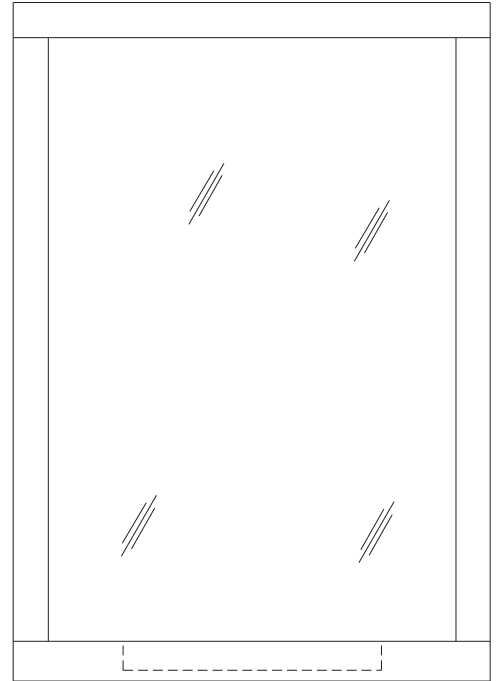

Security Enclosure Accessories

Installations, Inc. can fabricate several styles of security enclosures that are aesthetically appealing. Installations sales and engineering staff are on hand to help you with your security needs. Whether you need design consultation, product literature, fabrication or installation, please contact us for your security needs.

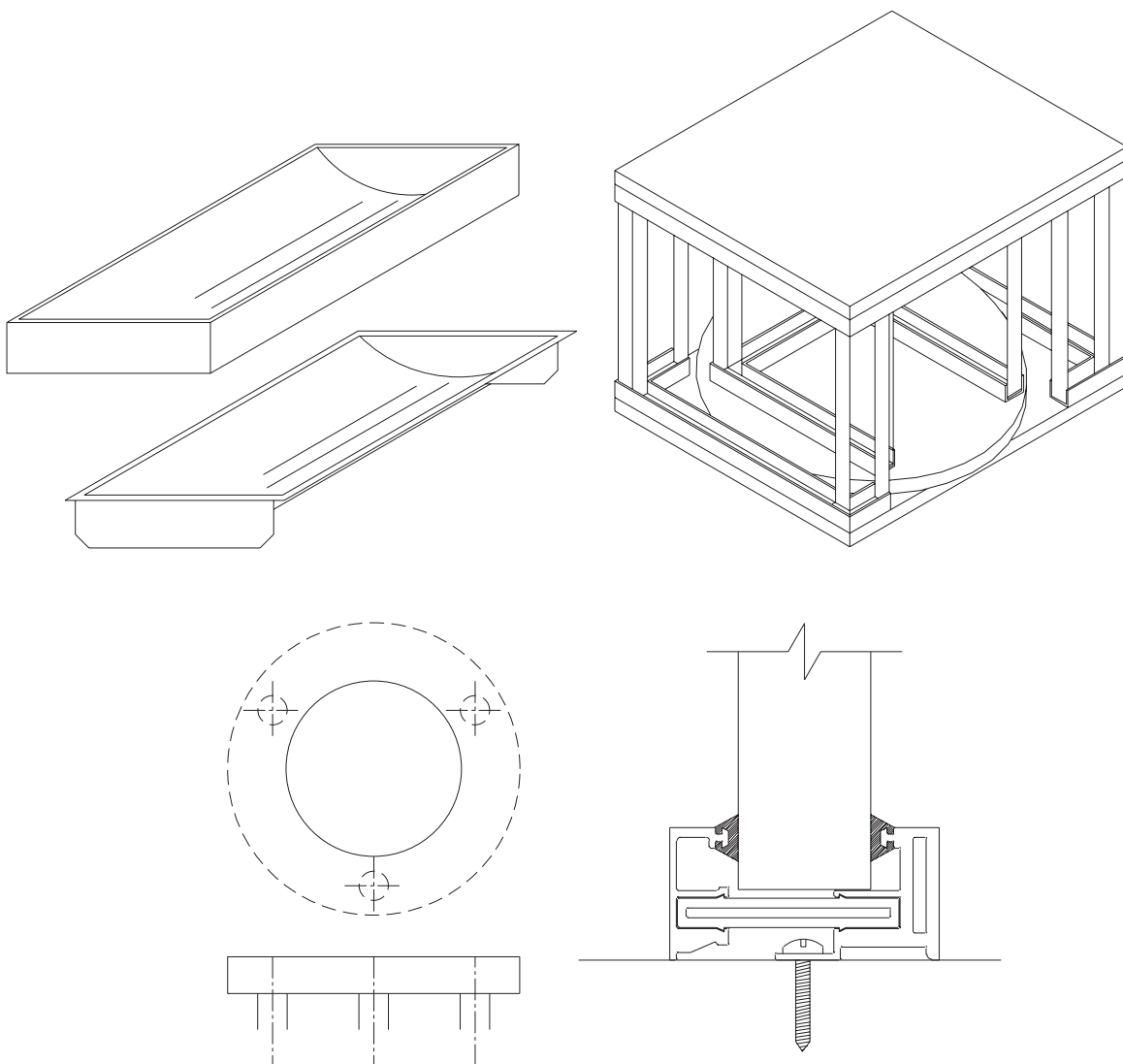

Revolving Package Exchange Unit

Product Description

Installations revolving package exchange unit can be fabricated out of level I, II or III glazing materials to meet your specifications. The unit is constructed with bullet resistant glazing materials on all sides and top to allow for full vision throughout. The bottom and disc are fabricated out of wood with a plastic laminate finish to match your decor.

Bullet Resistant Options:

Level I	1 1/4" uncoated acrylic
Level I	1 1/4" abrasion resistant acrylic
Level II	1 3/8" abrasion resistant acrylic
Level III	1 1/4" SP Polycast

Recommended Uses:

- Convenience Stores
- Gas Stations
- Fast Food Operations
- Police Stations

Benefits and Features:

- UL listed level I, II & III glazing materials
- Pass large packages securely
- Full vision unit
- Delivered complete and ready for installation

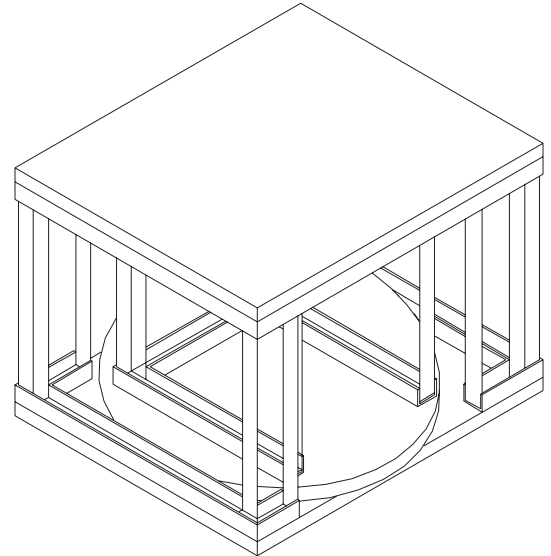

Recessed Money Tray

Product Description

Installations recessed money tray is constructed out of brushed stainless steel with a flange to mount within the existing countertop. The cash trays come standard in depth at 8" and height at 1 1/2" I.D. The width can be ordered to meet your specifications.

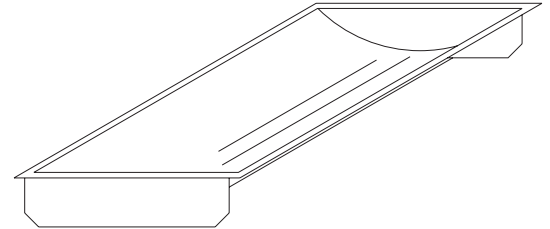

Recommended Uses:

- Financial Institutions
- Convenience Stores
- Gas Stations
- Fast Food Operations
- Police Stations

Benefits and Features:

- Easy cleaning
- Easy installation
- Drop in existing countertop
- Width custom fabricated to fit your existing specifications

Counter Mount Money Tray

Product Description

Installations counter mount money trays are constructed with brushed satin stainless steel and prepped for attachment to existing conditions. The cash trays come standard in depth at 8" and height at 2". The width can be ordered to meet your specifications.

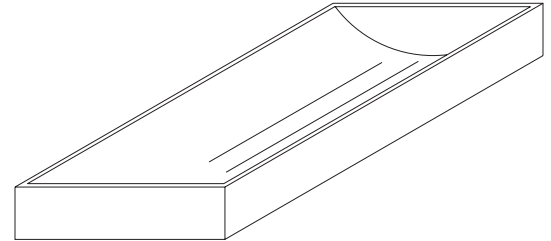

Recommended Uses:

- Financial Institutions
- Convenience Stores
- Gas Stations
- Fast Food Operations
- Police Stations

Benefits and Features:

- Easy cleaning
- Easy installation
- Counter cutout NOT required
- Width custom fabricated to fit your existing counter

Package Exchange Unit

Product Description

Installations package exchange unit is fabricated out of level I, II or III glazing materials to meet your specifications. The unit is constructed with bullet resistant glazing materials on all sides, doors and top for full vision throughout. The unit has a locking device that allows only one door to be open at a time.

Bullet Resistant Options:

Level I	1 1/4" uncoated acrylic
Level I	1 1/4" abrasion resistant acrylic
Level II	1 3/8" abrasion resistant acrylic
Level III	1 1/4" SP Polycast

Recommended Uses:

- Financial institutions
- Police stations
- Payment centers

Benefits and Features:

- UL listed level I, II & III glazing materials
- Only one door operational at a time.
- Full vision unit
- Delivered complete and ready for installation

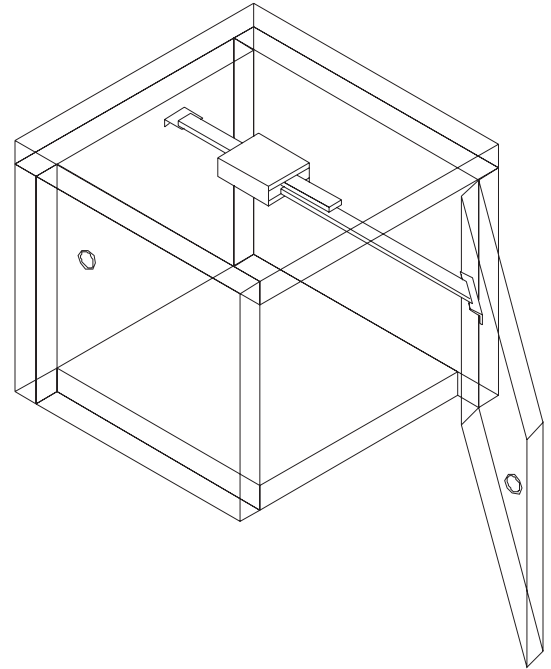

Steel Package Exchange Unit

Product Description

Installations steel package exchange unit is fabricated to meet level I, II or III ballistic levels to meet your specifications. The unit comes standard with a prime painted finish. Stainless steel doors, flanges and body are optional. The unit has a locking device that allows only one door to be open at a time.

Steel Finish Options:

All steel construction with prime painted finish
Steel body with stainless steel doors & flanges
All stainless steel construction
Custom painting available upon request

Recommended Uses:

- Financial Institutions
- Payment centers
- Police Stations

Benefits and Features:

- Fabricated to meet level I, II & III
- Only one door can be open at a time
- Delivered complete and ready for installation

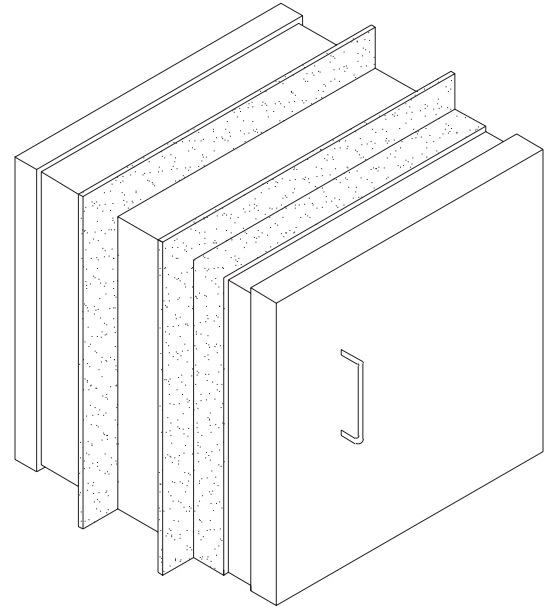

Exterior Pass Thru Drawer

Product Description

Installations exterior pass thru drawer is constructed out of stainless steel and UHMW for long lasting durability. The unit can be lined with level I, II & III ballistic fiberglass to meet your specifications. The unit has an acrylic lid to allow vision to the package being transferred. The pass thru drawer operates by a handle controlled by the employee and can be locked when not in use.

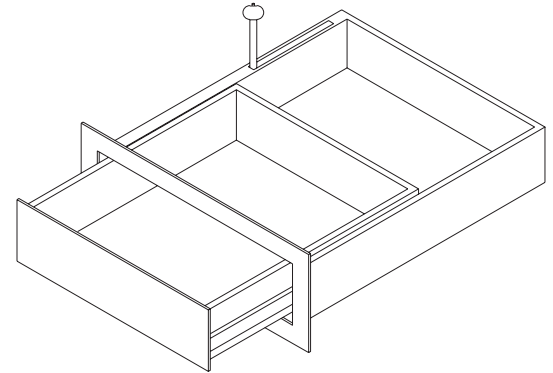

Bullet Resistant Options:

The drawer unit can be lined with Level I, II or III ballistic fiberglass

Finish Options:

Brushed stainless steel & UHMW construction

Recommended Uses:

- Convenience Stores
- Gas Stations
- Fast Food Operations
- Walk up windows

Benefits and Features:

- Level I, II & III BR lined
- Employee controls operation
- Full vision lockable lid.
- Delivered complete and ready for installation

Exterior Revolving Package Exchange Unit

Product Description

Installations exterior revolving package exchange units can be glazed with level I, II or III glazing materials to meet your specifications. The unit is constructed with a stainless steel housing and drum. The unit has a bullet resistant glazing lite to allow vision to the package being transferred. The package passer rotates 180 degrees by turning the top handle and can be locked when not in use.

Bullet Resistant Options:

Level I	1 1/4" uncoated acrylic
Level I	1 1/4" abrasion resistant acrylic
Level II	1 3/8" abrasion resistant acrylic
Level III	1 1/4" SP Polycast

Finishes:

Brushed stainless steel and UHMW construction

Recommended Uses:

- Convenience Stores
- Gas Stations
- Fast Food Operations
- Walk up windows

Benefits and Features:

- Level I, II & III glazing materials
- Stainless steel construction
- Delivered complete and ready for installation

